

Models 531, 532, 578 AND 588

POWER CYLINDER OPERATED VALVES

DESCRIPTION

These valves are ideal for use where minimum pressure drop is required or for applications where it is not practical to use the flowing stream as the power medium to operate a valve. Because the main piston is controlled externally, and by reason of the 45° body design, pressure drop through these valves is extremely low.

Standard power cylinders are designed to operate on 30 psi (207 kPa) minimum for full stroke and are limited to a maximum pressure of 150 psi (1034 kPa). An optional power cylinder for 15 psi (103 kPa) full stroke is available, but limited to selected applications that can tolerate a small leakage of the power cylinder operator pressure medium to atmosphere or sump.

The power cylinder may be operated either pneumatically or hydraulically with electric, pneumatic or hydraulic pilot valves used to control application or removal of pressure from the cylinder.

DESIGN FEATURES

- Fail safe on loss of power medium
- Modular construction - all internal parts including seat ring can be removed with the cylinder assembly without disturbing line connections.
- No diaphragms or stuffing boxes
- Linear control characteristics
- Positive shut-off
- Bi-directional flow
- 45° body design assures high capacity
- Extremely low pressure drop
- Atmospheric vent positively prevents mixing of line fluid and power cylinder operating fluid

APPLICATIONS

Tank safety, remote on-off control, bypass control on distribution system, emergency shut-off on loading and unloading lines. Two-stage and digital batch control.



⚠ WARNING

Do not operate this instrument in excess of the specifications listed. Failure to heed this warning could result in serious injury and/or damage to the equipment.

“AP”(AGGRESSIVE PRODUCTS) OPTION

The “AP” option valve cylinder incorporates a combination of seals and O-ring materials to provide optimum performance in aggressive product applications. This option includes reinforced cylinder heads, stat-o-seals, washers and gaskets. Specify “AP” Option at time of order when used on alcohols, MTBE, TAME and reformulated fuels.

PRINCIPLE OF OPERATION

These valves operate on a balanced piston principle, with a spring biased power cylinder operator. Spring loading of the power cylinder operator in the Model 531 is such that valve is normally closed, and reversed in the Model 532 so that it is normally open. The Model 578, 2-stage electric and Model 588 digital valve are both normally closed.

FLANGE CONNECTIONS / RATINGS (ANSI)

Valve Size	MAXIMUM WORKING PRESSURE @ 100° F		
	150 lbs. ANSI	300 lbs. ANSI	600 lbs. ANSI
2" - 12"	285 psi	740 psi	1480 psi

DISPLACEMENT OF POWER CYLINDER-FULL STROKE

Valve Size	2"	3"	4"	6"	8"	10"	12"
Displacement Cubic Inches	17.9	25.9	45	64.5	256	294	584

MATERIALS OF CONSTRUCTION

Main Valve

Main Valve Body

Steel - ASTM-A-216-GR-WCB

Main Valve Cylinder

2-6" Ductile Iron, Nickel Coated

8-12" Steel, Nickel Coated

Main Valve Piston

Bronze standard on 150 and 300 lb. valves.

Stainless Steel Optional.

Stainless Steel standard on 600 lb. valves.

Seat Ring

Steel, Nickel Coated (Stainless Steel-600

lb.valves)

O-Rings

Standard - Buna-N

Other O-rings available are Nitrile, EPR, all

Viton, all Buna-N, Kalrez, Teflon

Other Internal Parts

Stainless Steel

Power Cylinder Operator

Power Cylinder

Ductile Iron, Nickel Coated ASTM - 395

Power Cylinder Piston

Anodized Aluminum

Other Power Cylinder Internal Parts

Steel and Stainless Steel

FLANGE CONNECTIONS / RATINGS (DIN)

Valve Size	DIN PN16	DIN PN25	DIN PN40	DIN PN64 (300 lbs.)	DIN PN64 (600 lbs.)	DIN PN100
	MAX. WORKING PRESSURE @ 120°C	MAX. WORKING PRESSURE @ 120°C	MAX. WORKING PRESSURE @ 120°C	MAX. WORKING PRESSURE @ 38°C	MAX. WORKING PRESSURE @ 120°C	MAX. WORKING PRESSURE @ 38°C
DN50 - DN300	16 bar	25 bar	40 bar	51 bar	64 bar	100 bar

Temperature Range: -20°F to 150°F (-29°C to 66°C) Optional 250°F (121°C)

SHIPPING WEIGHT AND VOLUME (Approximate)

Size	150-300 lb. (ANSI Flg.)		600 lb. (ANSI Flg.)		150-300 lb. (ANSI Flg.)		600 lb. (ANSI Flg.)	
	lbs.	Kg.	lbs.	Kg.	Cubic Feet	Cubic Meters	Cubic Feet	Cubic Meters
2"	95	43.09	135	61.23	1.78	0.05	1.88	0.053
3"	120	54.43	165	74.84	2.67	0.076	2.81	0.08
4"	175	79.38	240	108.86	3.35	0.095	3.98	0.113
6"	290	131.54	440	199.58	5.86	0.166	7.52	0.213
8"	600	272.16	860	390.09	11.36	0.322	14.25	0.404
10"	870	394.63	1340	607.81	16.25	0.46	20.37	0.577
12"	1375	623.69	1980	898.11	25.18	0.713	28.13	0.797

VALVE CAPACITY DATA

Valve Size	2'	3'	4'	6'	8'	10'	12'
*C _v -gpm	86	186	309	688	1296	2040	2920

For capacities and pressure drops, please consult Bulletin DSVALVEC_v "Capacity Charts for Valve Sizing." *C_v based on wide open valve utilizing water at 60°F (15.6°C).

PRESSURE DROP

Refer to Publication DSVALVEC_v

OPTIONAL EQUIPMENT

1. Valve position indicator
2. Position indicator switches
3. Stainless steel main valve piston
4. Thermal relief
5. Additional pilot control functions
6. Three-way solenoid
7. Fusible link pilot valve (closes at 160°F)
8. Combination electrically controlled, pneumatic or hydraulic activated, single or two-stage shut-off (Model 531)
9. 15-150 psi (103-1034 kPa) power cylinder operator

RECOMMENDED SPARE PARTS

O-Rings

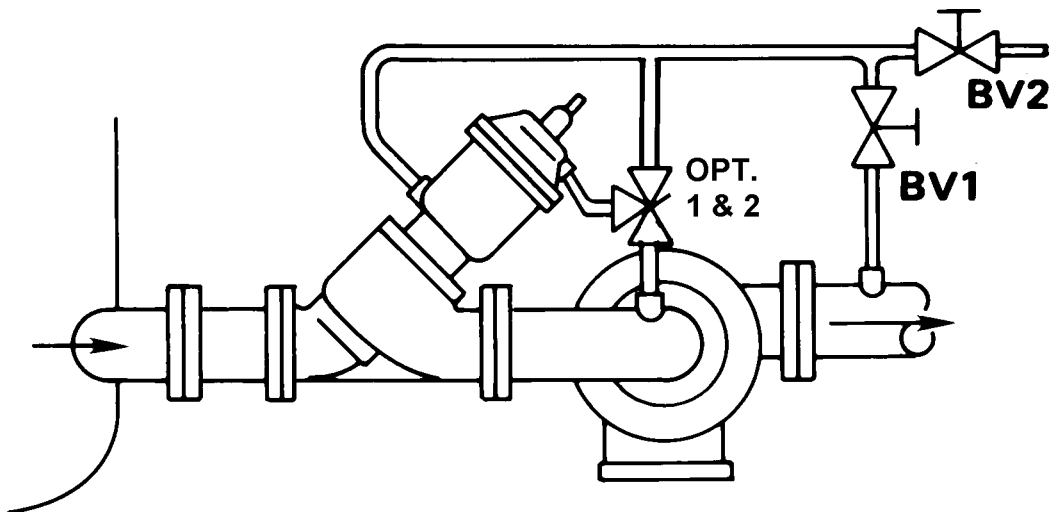

Figure 1 - Tank Control with Fire Protection and Remote Control

The Model 531 power cylinder operated control valves here described are installed as tank control or tank safety valves. Block valves 1 and 2 are for manual operation of the 531 when the line is emptied for installation or repair. Manual operation is required to fill the line with product before starting the pump and is accomplished by closing valve 1 and opening valve 2 for the admission of pressurized air or gas, not to exceed 100 psi (689 kPa) to the underside of the motor piston. To resume normal operations, open valve 1 and close valve 2.

When the pump is started the Model 531, as pictured in Figure 1, will automatically open due to pump differential pressure across the power cylinder piston. During operation the Model 531 is wide open and pressure loss is at a minimum.

When the pump is stopped, the pressure across the cylinder piston is equalized and the spring, being the differential force will immediately close the valve to prevent all flow.

Option 1 is a normally open spring loaded valve, held in a closed position by a fusible link, which will automatically close the Model 531 in case of fire. If fire occurs the fusible link will melt at 160°F, opening the spring loaded valve and equalizing the pressure across the power cylinder piston. The spring will force the Model 531 valve closed.

Option 2 is a solenoid operated pilot that provides the same service as the spring loaded valve but with the added feature of remote control. Various switches such as manual, thermal, pressure, or a combination of switches may be utilized. When the solenoid circuit is broken the Model 531 will close and remain closed until the solenoid is re-energized.

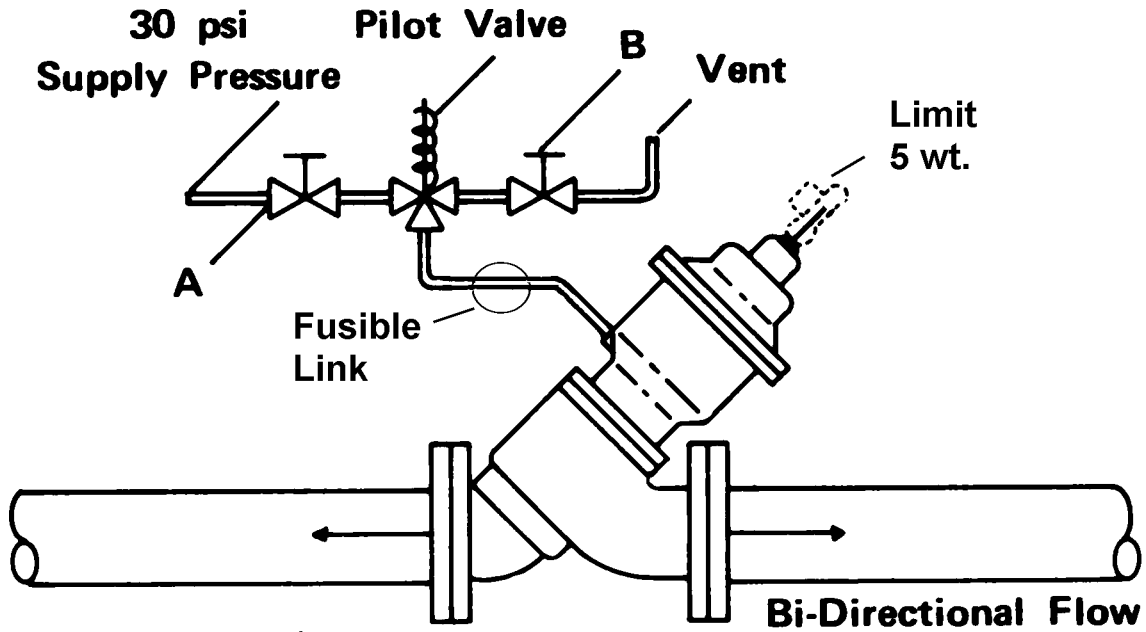
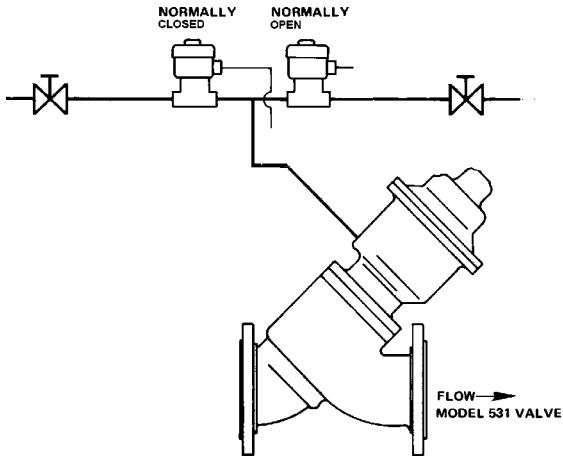

Figure 2 - Typical Remote On-Off

The installation, as shown, is typical for remote on-off or emergency shut-off in case of fire or line breakage. Energizing the solenoid of the three way pilot causes the main valve to open and to remain open during normal operation. The speed at which the main valve opens is controlled by needle valve "A".

When the power source is removed from the solenoid pilot, the power cylinder of the main valve is vented to atmosphere through needle valve "B". This needle valve may be adjusted to control the closing speed of the valve. Strategically located push button stations will permit the valve to be closed from several remote points in case of emergency.



Model 588 Digital Control

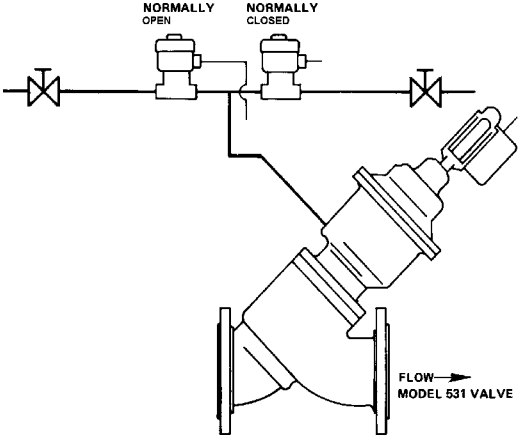

Model 558 Two-Stage Control

Figure 3 - Digital and Two-Stage

Model 588 Digital and Model 578 Two-stage valves are electrically operated from presets or batch control devices such as the PetroCount or mechanical presets. Energizing the solenoids opens the valves as described for figure 3. By using presets the valves can automatically be positioned for low flow start/stop, high flow and no flow. The 588 Digital will control flow rate. The solenoids control the position of the power cylinder by applying or venting the power source.

DIMENSIONS - (For certified dimension prints - consult factory)

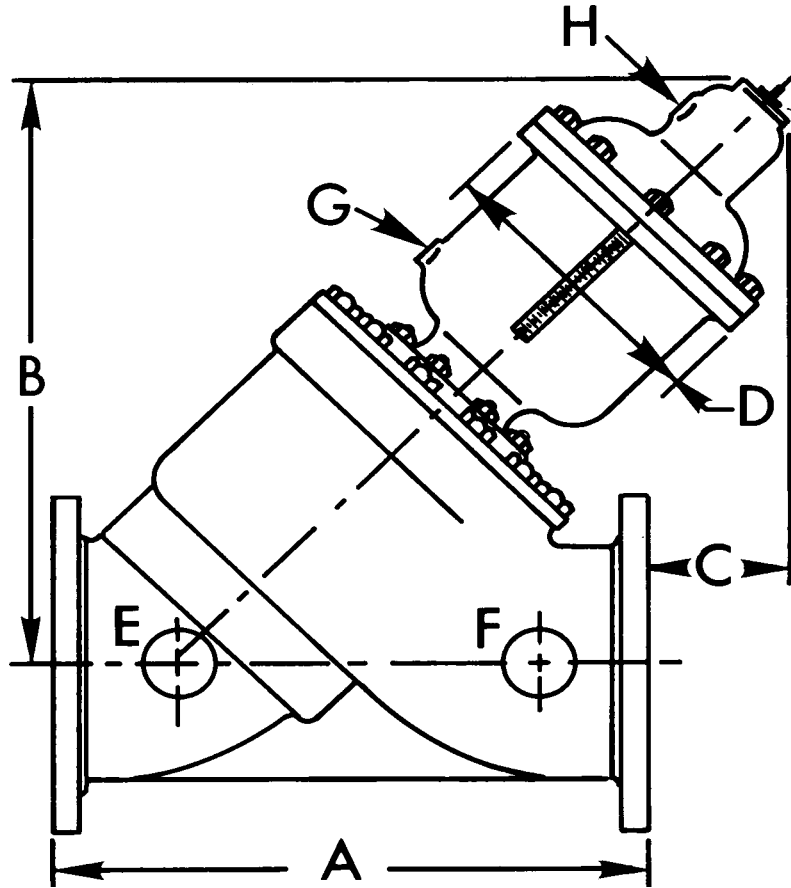

Size	Connections Sizes E,F,G and H
2"-6"	3/8"-18 NPT
8"-12"	1/2"-14 NPT

Valve Size	DIMENSION A (ANSI Flanges)						DIMENSION B (ANSI Flanges)		DIMENSION C (ANSI Flanges)		DIMENSION D (ANSI Flanges)	
	150 lbs.		300 lbs.		600 lbs.		150 lbs.		300 lbs.		600 lbs.	
	Inches	mm	Inches	mm	Inches	mm	Inches	mm	Inches	mm	Inches	mm
2"	10-1/4	260	10-1/2	267	11-1/2	292	13-3/4	349	5-3/8	137	6-5/8	168
3"	11	279	13-1/8	333	14	356	14-3/4	375	4-3/4	121	6-5/8	168
4"	13	330	14-1/2	368	17	432	15-3/8	391	4	102	8-1/2	216
6"	17	432	17-7/8	454	22	559	18-1/8	460	4-1/4	108	8-1/2	216
8"	22-1/4	565	23-1/4	591	26	660	25-3/8	645	7-7/8	200	13-3/8	340
10"	26-1/2	673	27-7/8	708	31	787	27-1/2	699	6-3/8	162	13-3/8	340
12"	30-7/8	784	33-5/8	854	36-1/2	927	31-3/8	797	6-1/2	165	15-1/2	394

PURCHASE SPECIFICATIONS

These valves shall be controlled by an integral piston operated power cylinder, utilizing a 30-150 psi (207-1034 kPa) operating medium. The main valve shall be pressure balanced, single seated, piston operated with 45° body construction. All internal parts, including cylinder, spring, piston and seat ring and power cylinder operator shall be removed as an integral unit without disturbing line connections. The main valve shall give bubble tight shut-off. The valve shall also be Fail Safe (Close or open on loss of power medium) and shall be in all respects, similar or equal to a Model 531 or 532 power operated control valve.

ORDERING INFORMATION

When ordering, the following information must be supplied:

1. Size
2. Product, product viscosity, product specific gravity
3. Minimum and maximum operating temperature
4. Minimum and maximum flow rate
5. Minimum, normal and maximum operating pressure
6. Control functions to be performed
7. Flange connections (150, 300, 600 lbs. ANSI)
8. O-Ring material
9. Control pilot materials
10. Tubing material
11. Voltage and frequency for electrical controls (if applicable)
12. Main valve piston material
13. Pilot cylinder operating pressure and medium
14. Optional equipment

The contents of this publication are presented for informational purposes only, and while every effort has been made to ensure their accuracy, they are not to be construed as warranties or guarantees, express or implied, regarding the products or services described herein or their use or applicability. We reserve the right to modify or improve the designs or specifications of such products at any time without notice.

DANIEL®

Daniel Division Headquarters - Houston, Texas, USA, Tel: (713) 467-6000, Fax: (713) 827-3880

USA Toll Free 1-888-FLOW-001

Calgary, Alberta, Canada, Tel: (403) 279-1879, Fax: (403) 236-1337

Stirling, Scotland - UK, Mid-East & Africa, Tel: +44 1653-638300, Fax: +44 1653-600425

Singapore - Asia Pacific Tel: +65- 777-8211, Fax: +65 -770-8001

www.daniel.com

Daniel is a wholly owned subsidiary of Emerson , and a division of Emerson Process Management.