

Email: ifc@islipflowcontrols.com

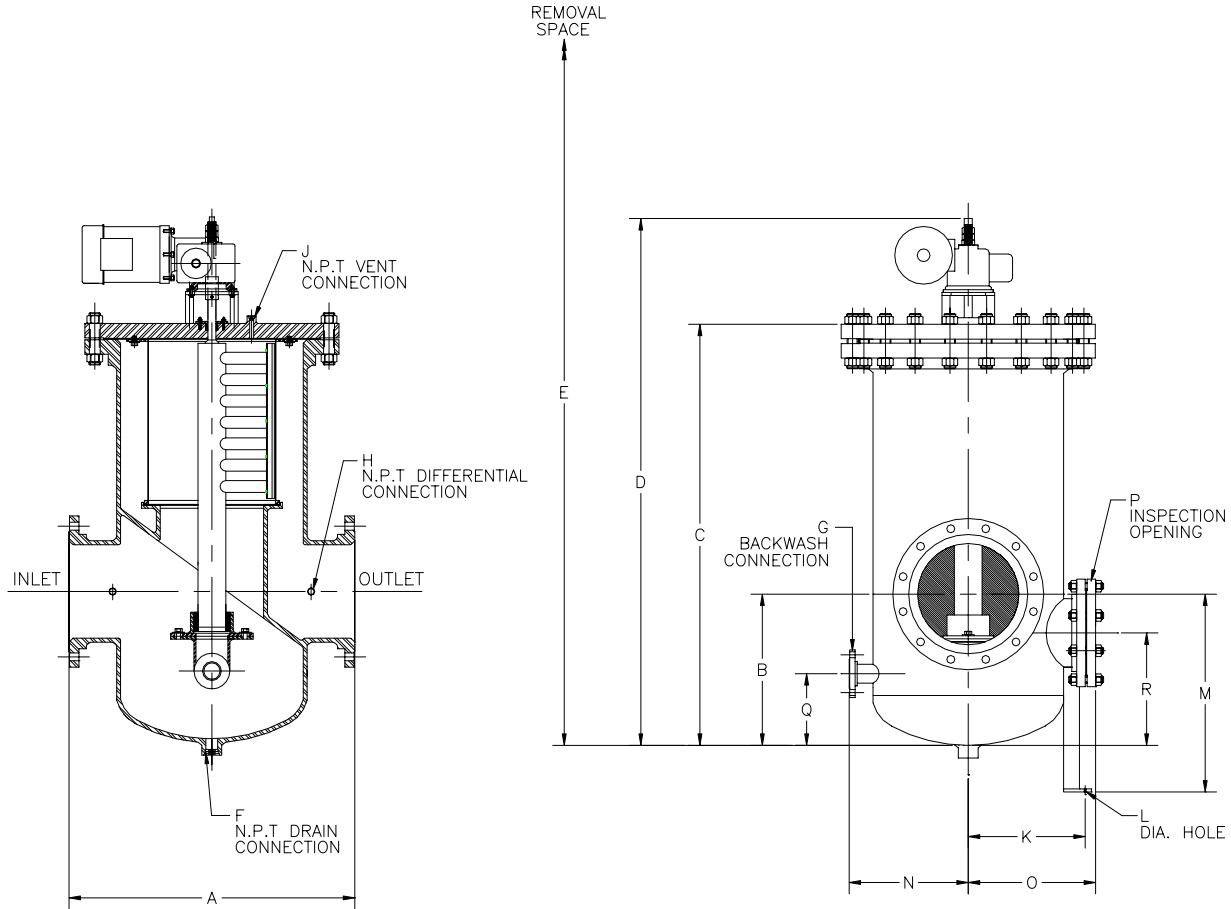

STRAINER SIZE	DIMENSIONS (INCHES)																	WEIGHT (LBS.)		
	A	B	C	D	E	F	G	H	J	K	L	M	N	O	P	Q	R	DRY	WET	COVER
10"	36	19	53	65.5	106	2	2	1/4	1/4	15	7/8	27	15	16	8	9	14	1200	1950	530
12"	36	19	53	65.5	106	2	2	1/4	1/4	15	7/8	27	15	16	8	9	14	1200	1950	530
14"	46	25	60	73.5	125	2	3	1/4	1/4	18.5	7/8	33	19	20	8	15	18	1700	3000	700
16"	46	26	66	79 1/2	138	2	3	1/4	1/4	18.5	1	34	19	20	8	15	18	1800	3100	700
18"	50	27	73	86 1/2	145	2	3	1/2	1/2	22 1/2	1	35	22	23	8	15	18	2600	4900	990
20"	50	30	79	92 1/4	170	2	4	1/2	1/2	22 1/2	1 1/8	38	23	23	12	16	20	2900	5400	1050
24"	64	32	87	100 1/2	188	3	4	1/2	1/2	28 1/8	1 1/8	40	29	30	12	16	22	4700	9700	1760
30"	78	45	125	142	245	3	4	1/2	1/2	36	1 3/8	53	35	36	12	22	34	8600	19500	2950
36"	96	53	140	158	274	4	6	1/2	1/2	46	1 3/8	61	44	46	12	24	40	14800	32000	4500

- Backwash sizes 2" and below are supplied as F.N.P.T. as standard. ANSI R.F. flanged connections are optional.
- Leg height can be modified to suit customer requirements.
- Dimensions may be modified to suit customer space and orientation requirements.
- Dimensions shown are subject to change. Contact factory for certified prints (exact dimensions) when required.

Email: [ifc@islipflowcontrols.com](mailto:ifc@islipflowcontrols.com)

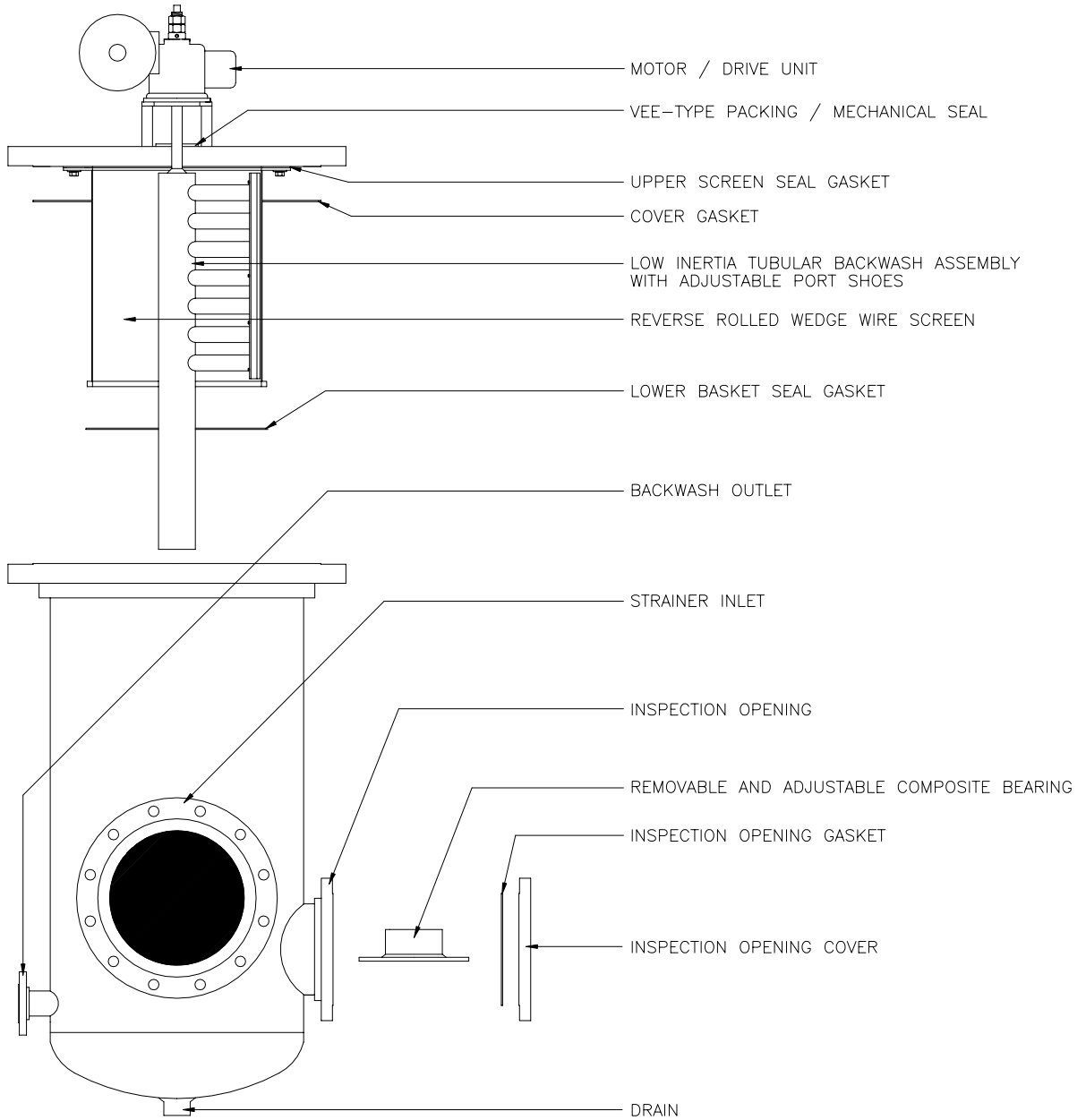

## IFC SELF-CLEAN-R STRAINER

1. All internal components are lifted from the strainer body upon cover removal.
2. Reverse rolled wedge wire screen exhibits both high strength and optimal performance.
3. Low inertia tubular backwash assembly increases backwash efficiency and minimizes power requirements.
4. Correctly proportioned outer annulus decreases pressure drop.
5. Superior quality construction with corrosion resistant internals.
6. Zero-Bypass. The straining element has both an upper and lower seat.
7. Full port backwash line results in no flow restriction.
8. Composite bearing requires no maintenance.
9. Large inspection port allows for inspection and removal of settled debris.
10. Large bottom chamber slows fluid velocity prior to straining.

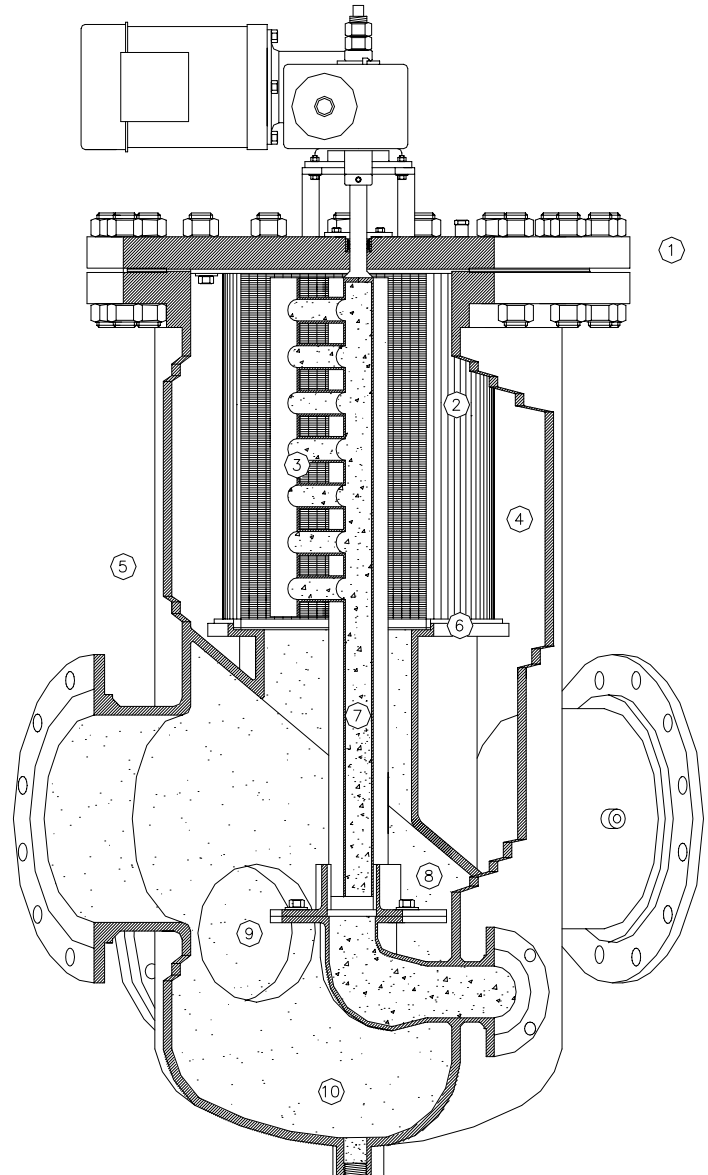

## **GENERAL OPERATION OF THE IFC SELF-CLEAN-R STRAINER**

The general operation of the IFC Self-Clean-R Strainer is outlined below.

1. The unfiltered fluid enters the strainer inlet into the lower single chamber. This chamber acts to both slow the fluid prior to straining and to collect any settled debris.
2. The fluid passes upward and then radially through the wedge wire straining element. Debris larger than the wedge wire slot size is unable to pass through the straining element.
3. The clean fluid continues through the properly proportioned flow path and out the strainer outlet.
4. When backwashing is initialized, either manually or automatically, the differential pressure between the line pressure and atmosphere is the driving force behind the backwashing process.
5. A hollow tubular backwash assembly which is piped to the atmosphere slowly rotates in close contact with the internal straining element. Only a small portion of the screen is isolated allowing for uninterrupted operation of the strainer during the backwashing process.
6. The pressure differential causes a large reverse flow across the screen and into the tubular backwash assembly. A port shoe, interconnecting the tubular backwash assembly, optimizes the effectiveness of this backwash jet stream.
7. Unwanted debris is carried into the full port backwash manifold and out the backwash connection. During the whole operation the flow remains uninterrupted keeping flow loss at a minimum.

The operation of the Self-Clean-R is controlled by an electrical panel, a actuated valve and a differential pressure switch. The cleaning cycle can be initiated manually, by differential pressure or by a timer.

## **MODES OF OPERATION FOR THE IFC SELF-CLEAN-R STRAINER**

There are two modes of operation for the IFC Self-Clean-R Strainer as outlined below:

---

### ***1/ Automatic Intermittent Mode***

This mode of operation is obtained by setting the selector switch located on the control panel to "AUTO". In this mode the frequency of backwashing is controlled by a adjustable timer (*1-10 min on time, 10 min to 10 hour off time*) located inside the control panel. The differential pressure switch (*Range 0-20 psid*) is used to override the timer and commence backwashing if the differential pressure across the strainer exceeds the set value.

---

### ***2/ Continuous Mode***

This mode is initiated by setting the selector switch to the "ON" position. During this mode of operation the strainer will continuously backwash the internal screen.

---